



**WHITES[®]
RURAL**

Posts • Fencing • Gates • Tools



Farm Fencing

2022 Rural Catalogue

www.whitesrural.com.au 



**WHITES[®]
RURAL**

Posts • Fencing • Gates • Tools

Australian family owned, down to earth, no nonsense

Whites Rural is Whites' specialist rural arm signifying a deep and long-term commitment to the fencing needs of rural Australia.

For 50 years, Whites has proudly been a 100% Australian owned and operated family business with its roots strongly embedded in steel, wire and fencing products.

Our long history of continuous improvement has yielded many new and unique product offerings, like Stockpost Ute Pack and Stockboss, always striving to provide greater value to farmers and fencing contractors in the rural market.

Most recently, Whites has introduced the Murray range – the new name in Australian-made fencing. Our manufacturing facility in Albury NSW, has state-of-the-art equipment and over 70 years' experience in producing rural fencing products.

FARM FENCING

Rural Catalogue



STOCKPOST Fence Posts

Stockpost	4-5
Stockpost Ute Pack	4-5
Stockpost XL	4-5
Stockfast	6
Stockboss	7
Stockpost End Assembly	8
Brace Kit	8

MURRAY Fencing & Gates

Fence Wire, Trellis Wire	10
Barbed Wire	11
Stiff Stay Farm Fencing	12
Stiff Stay Exclusion and Horse Fencing	13
Hinged Joint Farmplus	14
N-Stay Gates	16
Vertical Upright Gates	17
XHD Gates, Horse Mesh Gates	18
Ballimore Gates, Feral Gates	19
Sheep Yard Mesh, Tree Guards	20

WHITES RURAL

I-Stay Gates, Bar Gates	21
N-Stay Gates	22
Gate Fittings	23-24
Rural Netting	25
Farm Mesh, Dog Mesh	26
Fence Wire, Droppers, Farmlite	27
Drivers, Lifters, Spinners	28
Straining Tools	29
Stapling, Stockade	30-31
Fastening Tools, Stockade, Jambro	32
MaxTensor	33
Farm Pak Wire, Fencing Accessories	34
Pliers and Cutters	35

STOCKPOST®

Stockpost, Stockpost Ute Pack and Stockpost XL are premium fence posts – trusted, tried and true. Our Lifetime Guarantee is your assurance. Specifically designed with:

- Reformulated billet steel for greater ductility without mitigating strength
- Proprietary bituminous black coating providing a tough barrier against corrosion - it's not just paint
- Hot-dipped galvanised coating that meets the Australian Standard
- 1.9kg/m weight - a true heavy-weight fence post made from high-grade steel



STOCKPOST® UTE PACK®

Stockpost Ute Pack is Australian designed and patented and provides a faster fencing alternative to traditional slings. 200 Stockposts in a secure steel cradle... and no tie wires!

- Effortless Handling
 - packed as singles, no bundle to untie
- Easy Load Pack
 - front-end loader and ute - friendly size
- Refastenable Pack
 - use some or all, posts stay secure



STOCKPOST® XL

Stockpost XL is an intermediate post weighing in at 3.5kg/m and hot-rolled from the high grade Stockpost steel.

Featuring:

- 3 equal fins for all around stability
- More holes per post - ideal for feral fencing
- Easy to drive, heavyweight alternative to timber posts
- Packed in a faster fencing Ute Pack sling
- Supplied in packs of 50 (4:1 ratio – 200 Stockposts plus 50 Stockpost XLs provide a typical fencing ratio)



STOCKFAST[®]

Stockfast Latch-Post features five integrated stainless steel latch points for clipping barbed or plain wires, fast. The stainless steel latches have a positive-click to indicate the wire is secure. Post strength is assured as there are no ground level latch points.

Instead, five traditional holes below the lowest latch provide tie-off points for fencing closer to the ground. Another four holes higher up the post provide additional flexibility for individual fencing requirements

FASTER, EASIER

- Clip barbed or plain wires in less time than individual tie offs
- Simple and quick positive-click action

SMARTER, STRONGER

- Features five integrated latch-points
- No ground level latch-points - improves post integrity

Hole Spacing

Nine traditional TIE-OFF points

SPACING CHART

S/Steel LATCHES with galvanised RIVETS

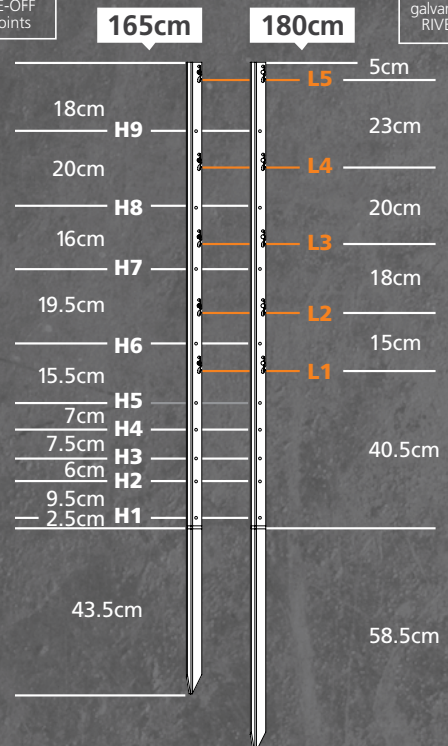

For barbed wire livestock fences



Code	Product	Size (ft)	Sling Qty	Weight (each)	Coating
STOCKFAST[®] - BLACK BITUMINOUS					
10835	165cm STOCKFAST - UTE PACK	5'6"	200	3.1kg	Black
10836	180cm STOCKFAST - UTE PACK	6'	200	3.4kg	Black

STOCKBOSS®

Stockboss fence post incorporates a unique corrosion-resistant wrap that has been independently tested to perform up to three times longer than traditional coatings.

Featuring Barrier-shield™ technology, the corrosion-resistant polymer wrap combines with the bituminous coating to form a dual barrier against difficult soils.

The wrap material is bonded to treated steel for an exceptional seal. It then extends 100mm above the ground for additional protection against differential corrosion in the critical zone above and just below the soil line.

The Stockboss Advantage

- Dual barrier coating
- Barrier-Shield™
- Above-ground protection
- Bonded to steel
- Salt-spray lab testing
- Field tested
- Unique line markings

Hole Spacings are the same as Stockpost.



Code	Product	Size (ft)	Sling Qty	Weight (each)	Coating
STOCKBOSS® - BLACK BITUMINOUS					
10831	165cm STOCKBOSS	5'6"	200	3.1kg	Black
10832	180cm STOCKBOSS	6'	200	3.4kg	Black

The Post That Stands Up To Corrosive Soils

1. Acidic, salt & alkaline soils

Severely reduce the life of regular steel posts that can look good above the ground but tell a different story below the ground

2. Zone of differential aeration

Protection from a combination of oxygen concentration and corrosive elements in the zone above and just below the soil line

3. In the ground

The protective polymer wrap works harder than traditional coatings to keep out corrosive elements underground

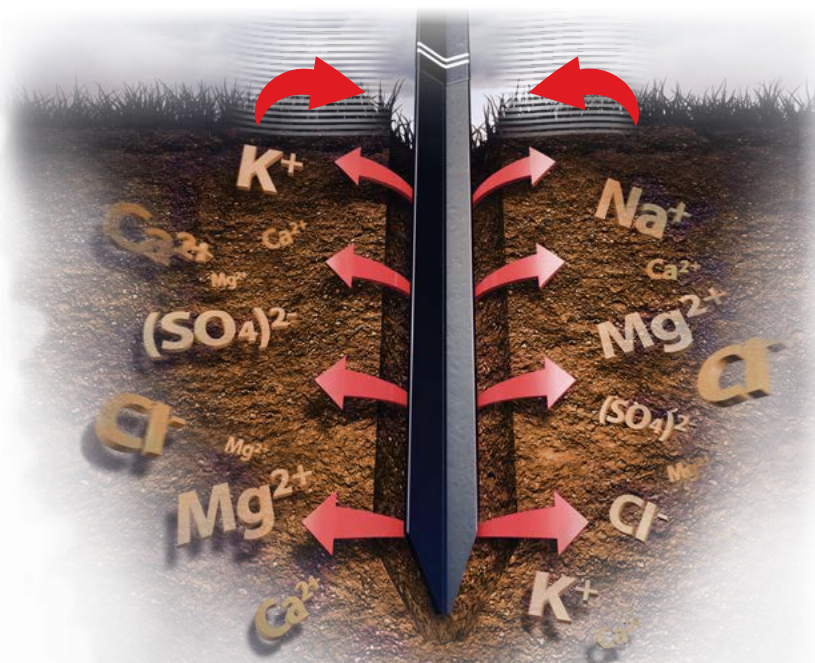

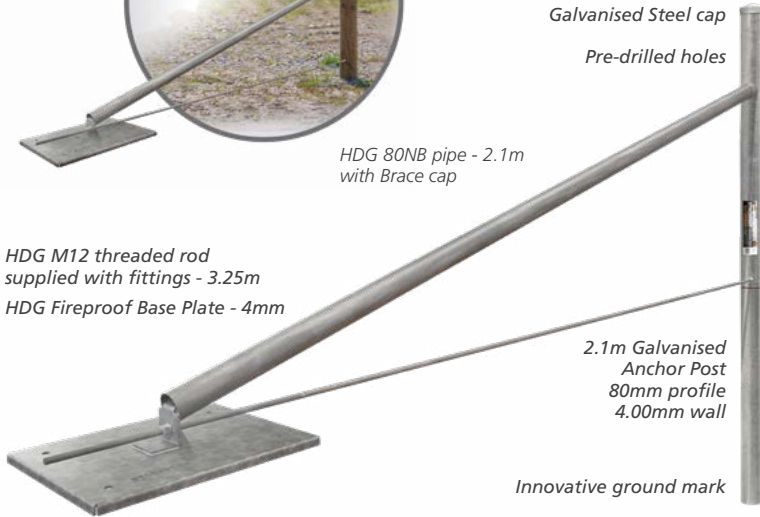

Code	Product	Pack Qty	Weight (each)
STOCKPOST[®] - END ASSEMBLY SYSTEM			
10880	STOCKPOST Round Strainer Post 2.1m	5	11kg
10870	STOCKPOST Anchor Post 2.1m	5	21kg
10875	STOCKPOST Stay Assembly 3m	5	17.1kg
STOCKPOST[®] - END ASSEMBLY ACCESSORIES			
10876	STOCKPOST Brace Cap with Spike	10	0.5kg
13855	End Assembly Gate Fitting Top Strap & Gudgeon	5	2.4kg
13856	End Assembly Gate Fitting Drop Latch & Eyelet	5	1kg

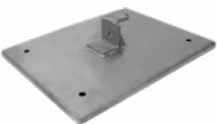

1. Fire-proof base plate



2. Stay clamp with brace cap



3. Wire rope with eyebolt



4. Galvanised post cap



Box of 4 Brace Kits

Code	Product	Weight kg
END ASSEMBLY BRACE KIT		
10878	End Assembly Brace Kit pk 4	32.8kg

STOCKPOST[®]

STOCKPOST[®] END ASSEMBLY

An end assembly system featuring two post types and a fully hot-dipped galvanised Stay Assembly Kit. Made to Stockpost's strict specifications.

Square Anchor Post:

Fully hot-dipped galvanised with shark-tooth design end, to cut through soil for effortless driving.

Round Strainer Post:

Australian-made (Albury NSW), and galvanised for a longer life.

Both posts feature Stockpost's unique ground mark, pre-drilled holes and heavy duty wall thicknesses.



fireproof base plate



innovative ground mark



pre-drilled holes & multiple configurations



heavy duty brace cap



clever edges to avoid compaction

END ASSEMBLY BRACE KIT

BRACE KIT

Whites Rural End Assembly Brace Kit includes:

- Fireproof base plate heavy duty, hot-dipped galvanised
- Stay clamp 100NB, with Brace Cap 50NB, hot dipped galvanised
- Wire rope with eyebolt 3.6m, 6 x 19 strand galvanised steel wire, hot-dipped galvanised bolt
- Post Cap 100NB, galvanised

The box comes with 4 sets of brace kits.

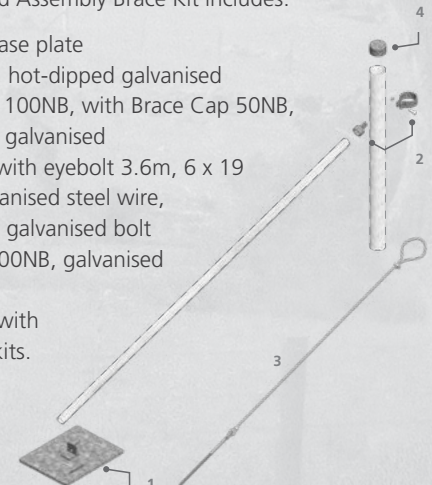

MURRAY™ STIFF STAY®

Murray Stiff Stay prefabricated fencing is *exclusively made* on the world-renowned Stiff Stay machines producing a tight, smooth knot in multiple configurations to suit farming requirements across the country.

MURRAY™ BARBED WIRE

Murray Barbed Wire is produced using the *latest and highest tolerance* barbed wire machines available today, the barbs are tightly twisted to prevent them slipping. All barbed wire is supplied on hardwood timber spools.

MURRAY™ GATES

Murray Gates are the *real heavyweights* in Australian-made gates. Produced with a tighter mesh aperture, 5mm pre-galv wire and featuring the latest notched welding techniques for extra strength and great looks.



BORN IN ALBURY AUSTRALIA

MURRAY STIFF STAY
with FOOTER
11 90 15
2.0mm
100m

Made in Australia
100% Australian Owned & Operated

Scan for more information





FENCE WIRE

Murray Fence Wire is coiled at our Albury Manufacturing facility in regional Australia and available in four grades:

High Tensile Wire

- Suited to longer strains/fence runs and wider post spacings where strength is imperative
- Heavily galvanised, lasts four times longer than standard galvanised wire

Medium Tensile Wire

- Easier to handle than HT, ideal with prefab fencing
- Heavily galvanised, last four times longer than standard galvanised

Soft Tensile Wire

- Easiest to handle, cost effective
- More fire resistant than HT/MT wire – ideal for fire prone areas

Tie Wire

- Easiest to handle and tie, cost effective



Coiled for smooth,
tangle-free pay-off



Scan
for more
information

Coiled in Australia

100% Australian Owned & Operated

Code	Wire	Tensile Strength	Coil Length	Coil Weight	Sling Qty	Galv. Coating	Rec. Tension Breaking Strain
HEAVILY GALVANISED FENCE WIRE							
10014	2.50mm	Medium	1500m	58kg	10	Heavy	1.3kn, 3.7kn
10015	2.50mm	High	1500m	58kg	10	Heavy	1.8kn, 5.4kn
10016	2.80mm	High	1000m	48kg	10	Heavy	2.0kn, 6.8kn
10017	3.15mm	Soft	750m	46kg	10	Heavy	1.2kn, 3.0kn
10018	4.00mm	Soft	500m	50kg	10	Heavy	1.8kn, 4.8kn
STANDARD GALVANISED FENCE WIRE							
10161	4.00mm	Soft	500m	49kg	10	Standard	1.8kn, 4.8kn
10163	3.15mm	Soft	750m	46kg	10	Standard	1.2kn, 3.0kn
10170	2.50mm	Medium	1500m	58kg	10	Standard	1.3kn, 3.7kn
10171	2.50mm	High	1500m	58kg	10	Standard	1.8kn, 5.4kn
STANDARD GALVANISED TIE WIRE							
10164	2.50mm	Soft	1300m	50kg	10	Standard	1.3kn, 3.7kn
10165	2.00mm	Soft	2000m	50kg	10	Standard	-
10166	1.57mm	Soft	3200m	50kg	10	Standard	-

TRELLIS WIRE

Murray Trellis Wire is made at our Albury Manufacturing facility in regional Australia, using premium grade wire.

- Heavily galvanised to last up to 4 times longer
- Made with high tensile wire to the highest tolerance
- Smooth tangle-free delivery

Use with Agri-Wire Strainer – a traditional cam-lock style strainer used in vineyards.



Scan
for more
information

Made in Australia

100% Australian Owned & Operated

Code	Wire	Tensile Strength	Coil Length	Coil Weight	Sling Qty	Coating	Rec. Tension Breaking Strain
TRELLIS WIRE							
10022	2.00mm	High	2000m	44kg	10	Hvy Gal	1.0kn, 2.7kn
10023	2.65mm	High	1000m	44kg	10	Hvy Gal	2.0kn, 6.0kn
10024	2.85mm	High	1000m	50kg	10	Hvy Gal	2.2kn, 8.3kn
10026	3.15mm	High	1000m	61kg	10	Hvy Gal	3.1kn, 9.4kn



MURRAY

FENCE WIRE



WHITES RURAL

BARBED WIRE

Murray Barbed Wire is made at our Albury Manufacturing facility in regional Australia.

High Tensile Wire Barbed Wire

- Made from high tensile wire in a continuous length for added strength – no joins
- Reverse twist pattern absorbs heavy loads by 'unwinding' and 'rewinding' under stock pressure
- Barb spacing is consistent and close with limited movement
- Available in Heavily Galvanised 1.57mm, 1.80mm and 2.00mm HT wire
- Meets AS2423 Australian Standard

IOWA Barbed Wire

- Made from 2.50mm soft/low tensile wire in a continuous length – no joins
- Continuous twist pattern locks the barbs in place limiting movement with stock pressure
- Barb spacing is consistent and close with limited movement
- More fire resistant than high tensile – ideal for fire prone areas
- Softer wire is easier to work with than high tensile



Reverse Twist Style
for optimum strength
and tensioning



Continuous Twist Style



Continuous Length
- No Joins



**Coiled on
hardwood spools**



Scan for more information

Made in Australia

100% Australian Owned & Operated

Code	Wire	Tensile Strength	Coil Length	Coil Weight	Pallet Qty	Galv. Coating	Rec. Tension Breaking Strain
HIGH TENSILE BARBED WIRE							
10100	2.00mm	High	500m	37kg	36	Heavy	1.6kn, 5.0kn
10101	1.80mm	High	500m	28kg	32	Heavy	1.3kn, 4.0kn
10102	1.57mm	High	500m	24kg	48	Heavy	1.3kn, 3.0kn
IOWA BARBED WIRE							
10150	2.50mm	Soft	400m	45kg	27	Standard	1.3kn, 3.0kn
10151	2.50mm	Soft	400m	45kg	27	Heavy	1.3kn, 3.0kn



STIFF STAY®

FARM FENCING

Murray Stiff Stay prefabricated fencing is made exclusively on the Stiff Stay machine at our Albury Manufacturing facility in regional Australia.

- Popular 30cm and 15cm picket spacings
- Heavily Galvanised to AS4534
- 2.80mm high tensile top and bottom wires for added strength (Heavy Galv only)
- 2.50mm high tensile line wires and 2.50mm vertical stay wires

Also available in Standard Galvanised to AS4534 with 2.50mm high tensile line wires and 2.50mm vertical stay wires

Spacing Chart

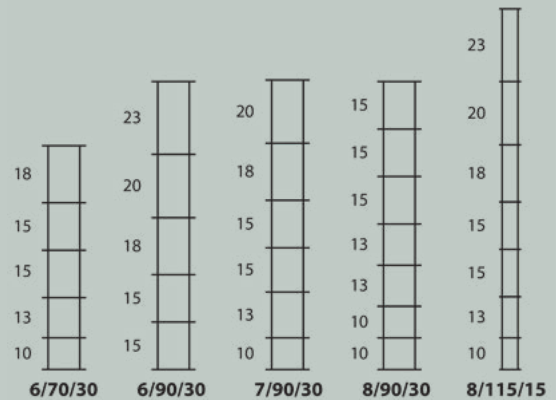

Continuous vertical pickets that are locked into place to resist buckling and sagging



Better over uneven terrain, resist sagging



Pre-stripped rolls for faster fencing – no need to strip picket wires; the first two pickets and the last two pickets are removed



Tension crimps provide a quick visual for judging tension



Scan for more information

Made in Australia
100% Australian Owned & Operated



Heavily Galv. Code (Weight)	Standard Galv. Code (Weight)	Product	Roll Length	Tensile Strength	Pallet Qty
STIFF STAY® FABRICATED FARM FENCING					
10231 (72kg)	A0201 (68kg)	6/70/30	200m	High	9
A0261 (180kg)		6/70/30	500m	High	4
10232 (78kg)		6/90/30	200m	High	9
A0262 (195kg)		6/90/30	500m	High	4
10233 (86kg)	10203 (81kg)	7/90/30	200m	High	9
10263 (215kg)	10223 (202kg)	7/90/30	500m	High	4
10238 (63kg)		8/90/15	100m	High	9
A0266 (156kg)		8/90/15	250m	High	4
10234 (94kg)	A0204 (89kg)	8/90/30	200m	High	9
A0265 (235kg)		8/90/30	500m	High	4
10239 (69kg)		8/115/15	100m	High	9
A0269 (172kg)		8/115/15	250m	High	4



MURRAY

STIFF STAY®



WHITES RURAL®

EXCLUSION FENCING

Murray Stiff Stay prefabricated fencing is made exclusively on the Stiff Stay machine at our Albury Manufacturing facility in regional Australia.

- Narrow 15cm picket spacings
- Heavily Galvanised to AS4534
- 2.80mm high tensile top and bottom wires for added strength
- 2.50mm high tensile line wires and 2.50mm vertical stay wires

Optional pre-attached hinge apron to restrict penetration or digging under the fence

Spacing Chart

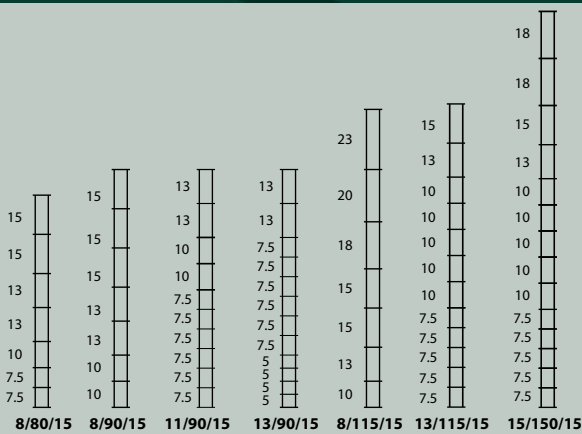

Heavily Galv. Code (Weight)	Product	Hinged Apron	Roll Length	Tensile Strength	Pallet Qty
STIFF STAY® EXCLUSION FENCING					
10235 (62kg)	8/80/15		100m	High	9
10238 (63kg)	8/90/15		100m	High	9
A0266 (156kg)	8/90/15		250m	High	4
A0268 (209kg)	8/90/15	30cm 3-line	250m	High	4
10289 (76kg)	11/90/15		100m	High	9
10285 (97kg)	11/90/15	30cm 4-line	100m	High	9
10251 (86kg)	13/90/15		100m	High	9
10255 (106kg)	13/90/15	30cm 3-line	100m	High	9
10239 (69kg)	8/115/15		100m	High	9
A0269 (172kg)	8/115/15		250m	High	4
A0271 (225kg)	8/115/15	30cm 3-line	250m	High	4
10259 (92kg)	13/115/15		100m	High	9
A0273 (140kg)	13/115/15	30cm 3-line	100m	High	9
A0272 (228kg)	13/115/15		250m	High	4
A0274 (281kg)	13/115/15	30cm 3-line	250m	High	4
10260 (118kg)	15/150/15		100m	High	9
A0276 (130kg)	15/150/15	30cm 3-line	100m	High	9
A0275 (273kg)	15/150/15		250m	High	4
A0277 (325kg)	15/150/15	30cm 3-line	250m	High	4
A0278 (651kg)	15/150/15	30cm 3-line	500m	High	1



Scan for more information

Made in Australia

100% Australian Owned & Operated

HORSE FENCING

Murray Stiff Stay prefabricated fencing is made exclusively on the Stiff Stay machine at our Albury Manufacturing facility in regional Australia.

- Super-tight 5cm picket spacings
- Heavily Galvanised to AS4534
- 2.80mm high tensile top and bottom wires for added strength
- 2.50mm high tensile line wires and 2.50mm vertical stay wires

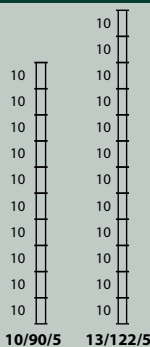

Heavily Galv. Code (Weight)	Product	Roll Length	Tensile Strength	Pallet Qty
STIFF STAY® HORSE FENCING				
10264 (68kg)	10/90/5	50m	High	9
10256 (93kg)	13/122/5	50m	High	9



HINGED JOINT

FARM FENCING

Murray Hinged Joint prefabricated fencing is made at our Albury Manufacturing facility in regional Australia.

- 30cm picket spacings ideal for stock, boundary and internal fencing
- 15cm picket spacing for more intensive farming
- Galvanised to AS4534
- 2.50mm high tensile line wires and 2.50mm vertical stay wires

Also available in Heavily Galvanised to AS4534

Spacing Chart

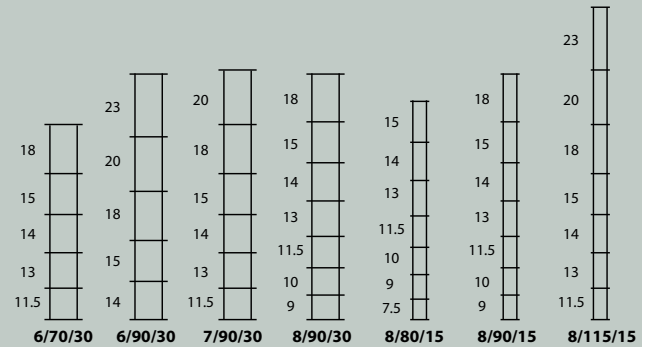

Code	Product	Tensile Strength	Roll Length	Roll Weight	Pallet Qty	Galv. Coating	Line Wire
STANDARD GALVANISED HINGED JOINT							
10291	6/70/30	High	200m	70kg	9	Standard	2.5mm
10292	6/90/30	High	200m	74kg	9	Standard	2.5mm
10293	7/90/30	High	200m	83kg	9	Standard	2.5mm
10294	8/90/30	High	200m	92kg	9	Standard	2.5mm
10295	8/80/15	High	100m	60kg	9	Standard	2.5mm
10298	8/90/15	High	100m	61kg	9	Standard	2.5mm
10299	8/115/15	High	100m	69kg	9	Standard	2.5mm
HEAVY GALVANISED HINGED JOINT							
A0311	6/70/30	High	200m	76kg	9	Heavy	2.5mm
A0312	6/90/30	High	200m	81kg	9	Heavy	2.5mm
A0313	7/90/30	High	200m	90kg	9	Heavy	2.5mm
A0314	8/90/30	High	200m	99kg	9	Heavy	2.5mm
A0315	8/80/15	High	100m	63kg	9	Heavy	2.5mm
A0318	8/90/15	High	100m	67kg	9	Heavy	2.5mm
A0319	8/115/15	High	100m	74kg	9	Heavy	2.5mm



Scan for more information

Made in Australia

100% Australian Owned & Operated



Code	Product	Tensile Strength	Roll Length	Roll Weight	Pallet Qty.	Galv. Coating	Line Wire
FARMPPLUS™ HINGED JOINT							
10283	8/115/15	Medium	100m	48kg	9	Standard	2.0mm



Scan for more information

Made in Australia

100% Australian Owned & Operated

FARMPPLUS™

- Narrow 15cm picket spacings for intensive farming
- Galvanised to AS4534
- 2.50mm high tensile top and bottom wires with 2.00mm high tensile line wires and 2.50mm vertical stay wires



MURRAY

GATES

The Murray Difference

- Tight 150 x 100mm aperture x 5mm wire on Murray-standard gates
- Super-tight horse mesh gates 50 x 100mm aperture x 5mm wire
- More wire, more weight

Notched Welding

- Fitted & shaped for extra strength
- Cleaner, stronger welds for longer service life

Extra Strength

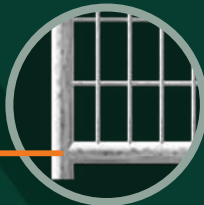

All Murray gates feature improved notched welding

- Made in Australia
- Pipe is hot-dip galvanised inside and out to AS1074
- Mesh cut-outs designed to accommodate gate fittings - no fiddly cuts required
- Available in 1ft (0.3m) increments up to 20ft (6m)
- "Shut the gate mate!" sign (included on all gates)



Scan for more information

Made in Australia

100% Australian Owned & Operated



WHITES RURAL

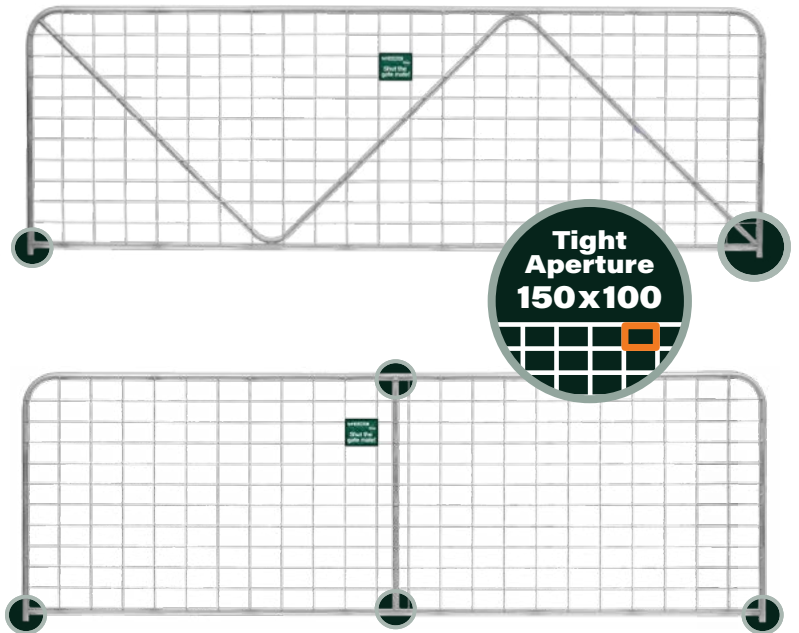

The real HEAVYWEIGHTS in Aussie-made gates

GATES

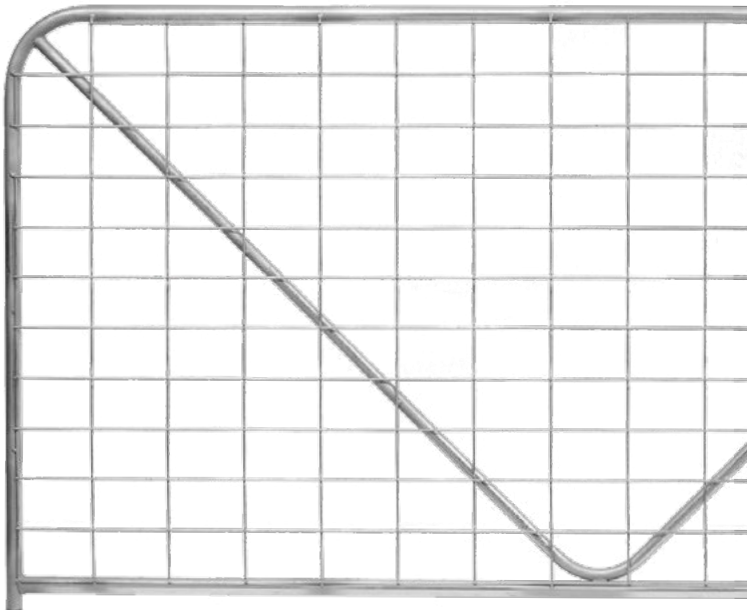

'N' STAY GATES

Murray N Stay, V Stay and M Stay gates are manufactured at our Albury Manufacturing facility in regional Australia and feature:

- 5mm pre-galvanised wire mesh
- Tight 150mm x 100mm aperture
- 350 grade high tensile 25NB pipe
- All pipe is 2mm thick and hot-dip galvanised inside and out
- 'N' Stays available in matching left & right pairs
- Fully welded notched joints to resist cracking
- 1170mm high
- Murray 'Shut the Gate Mate' sign

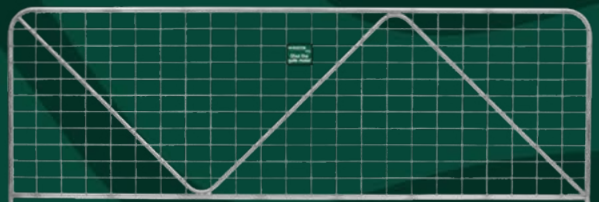

Scan for more information

Made in Australia

100% Australian Owned & Operated

Code	Stay Type	Weight (kg)	Nominal mm (ft)	Actual (mm)	Weld Mesh (mm)
'N' 'V' 'M' STAY FARM GATES					
AVG08	"V"	22kg	2440(8'0")	2390	150x100x5
AVG09	"V"	24kg	2745(9'0")	2695	150x100x5
ANS10	"N"	27kg	3050(10'0")	3000	150x100x5
ANS11	"N"	29kg	3350(11'0")	3300	150x100x5
ANS12	"N"	31kg	3660(12'0")	3610	150x100x5
ANS13	"N"	33kg	3960(13'0")	3910	150x100x5
ANS14	"N"	36kg	4270(14'0")	4220	150x100x5
ANS15	"N"	38kg	4570(15'0")	4520	150x100x5
ANS16	"N"	40kg	4880(16'0")	4830	150x100x5
ANS18	"N"	42kg	5484(18'0")	5434	150x100x5
ANS20	"M"	45kg	6095(20'0")	6045	150x100x5



MURRAY

GATES



WHITES RURAL

VERTICAL UPRIGHT GATES

Murray Vertical Upright gates are manufactured at our Albury Manufacturing facility in regional Australia and feature:

- 5mm pre-galvanised wire mesh
- Tight 150mm x 100mm aperture
- 350 grade high tensile 25NB pipe
- All pipe is 2mm thick and hot-dip galvanised inside and out
- Fully welded notched joints to resist cracking
- 1170mm high
- Murray 'Shut the Gate Mate' sign

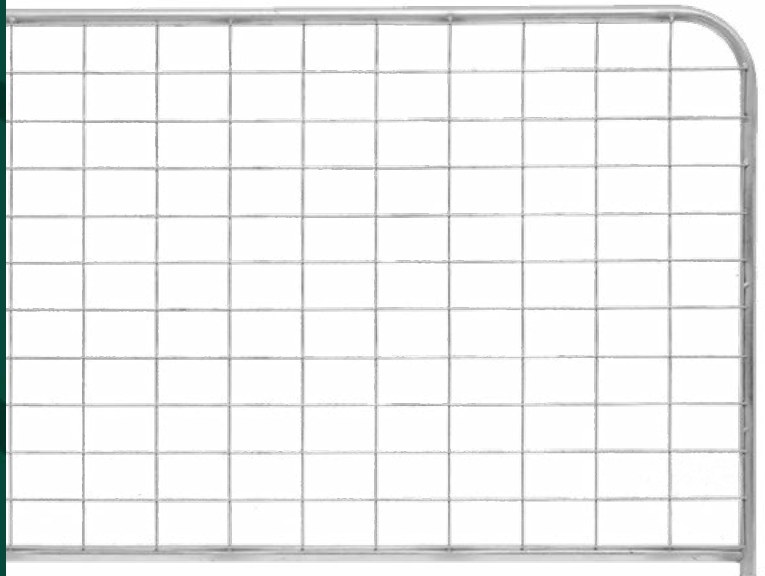

25NB pipe



5mm wire diameter



Improved Notched Welding



Tight Aperture 150x100

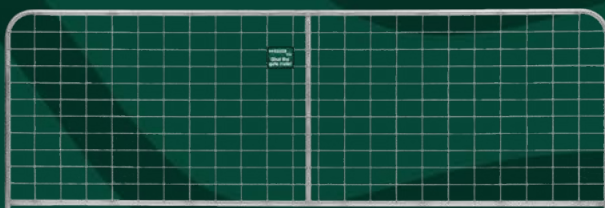

Scan for more information

Made in Australia

100% Australian Owned & Operated

Code	Stay Type	Weight (kg)	Nominal mm (ft)	Actual (mm)	Weld Mesh (mm)
VERTICAL UPRIGHT FARM GATES					
AMS03	-	9kg	915(3'0")	865	150x100x5
AMS04	-	11kg	1220(4'0")	1170	150x100x5
AMS05	"I"	14kg	1525(5'0")	1475	150x100x5
AMS06	"I"	16kg	1830(6'0")	1780	150x100x5
AMS07	"I"	18kg	2135(7'0")	2085	150x100x5
AMS08	"I"	19kg	2440(8'0")	2390	150x100x5
AMS09	"I"	21kg	2745(9'0")	2695	150x100x5
AMS10	"I"	23kg	3050(10'0")	3000	150x100x5
AMS11	"I"	25kg	3350(11'0")	3300	150x100x5
AMS12	"I"	27kg	3660(12'0")	3610	150x100x5
AMSD2	"II"	29kg	3660(12'0")	3610	150x100x5
AMS13	"II"	31kg	3960(13'0")	3910	150x100x5
AMS14	"II"	32kg	4270(14'0")	4220	150x100x5
AMS15	"III"	36kg	4570(15'0")	4520	150x100x5
AMS16	"III"	38kg	4880(16'0")	4830	150x100x5
AMS18	"III"	40kg	5484(18'0")	5434	150x100x5
AMS20	"IIII"	43kg	6095(20'0")	6045	150x100x5

GATES

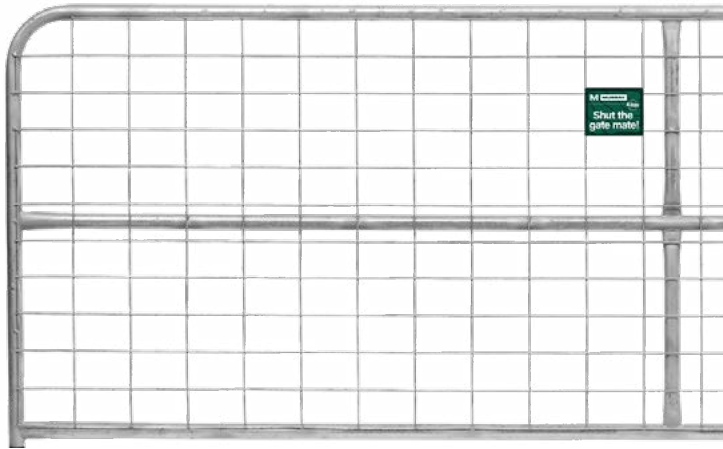

XHD GATES

Murray XHD Gates are manufactured at our Albury Manufacturing facility in regional Australia and feature:

- 5mm pre-galvanised wire mesh
- Tight 150mm x 100mm aperture
- 350 grade high tensile 32NB pipe frame
- Pipe frame is 2.6mm thick and hot-dip galvanised inside and out
- Fully welded notched joints to resist cracking
- 1170mm high
- Murray 'Shut the Gate Mate' sign

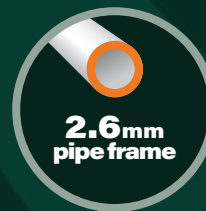

Scan
for more
information

Made in Australia
100% Australian Owned & Operated

Code	Nominal mm (ft)	Actual (mm)	Weight (kg)	Stay Type	Frame Pipe	Stay Pipe	Weld Mesh (mm)
XHD N-STAY FARM GATES							
AXN10	3050 (10'0")	3000	33kg	"N"	32NB	25NB	150x100x5
AXN12	3660 (12'0")	3610	40kg	"N"	32NB	25NB	150x100x5
AXN14	4270 (14'0")	4220	47kg	"N"	32NB	25NB	150x100x5
AXN16	4880 (16'0")	4830	53kg	"N"	32NB	25NB	150x100x5
XHD UPRIGHT FARM GATES - CROSSBAR							
AXB08	2440 (8'0")	2390	30kg	"I"	32NB	32NB	150x100x5
AXB10	3050 (10'0")	3000	36kg	"I"	32NB	32NB	150x100x5
AXB12	3660 (12'0")	3610	42kg	"I"	32NB	32NB	150x100x5
AXB14	4270 (14'0")	4220	50kg	"II"	32NB	32NB	150x100x5
AXB16	4880 (16'0")	4830	59kg	"III"	32NB	32NB	150x100x5

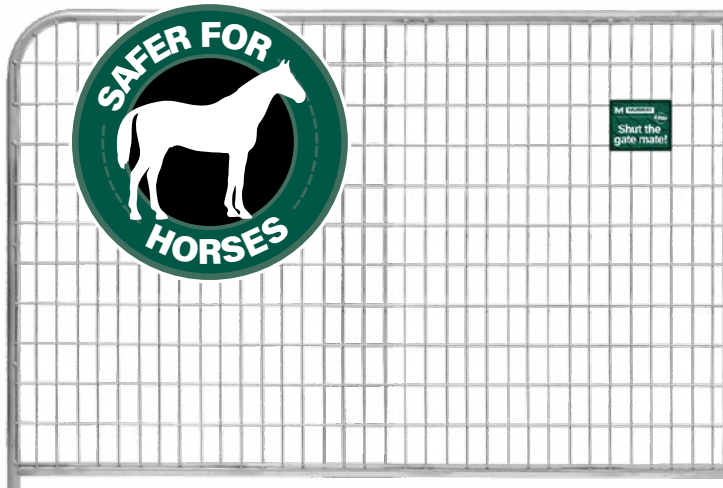

HORSE MESH GATES

Murray Horse Mesh Gates are manufactured at our Albury Manufacturing facility in regional Australia and feature:

- 5mm pre-galvanised wire mesh
- Super-tight 50mm x 100mm aperture
- 350 grade high tensile 25NB pipe
- All pipe is 2mm thick and hot-dip galvanised inside and out
- Fully welded notched joints to resist cracking
- 1170mm high
- Murray 'Shut the Gate Mate' sign



Scan
for more
information

Made in Australia
100% Australian Owned & Operated

Code	Nominal mm (ft)	Actual (mm)	Weight (kg)	Stay Type	Weld Mesh (mm)
HORSE MESH FARM GATES - UPRIGHT					
AHI03	915 (3'0")	865	5kg	-	100x50x5
AHI04	1220 (4'0")	1170	6kg	-	100x50x5
AHI06	1830 (6'0")	1780	9kg	"I"	100x50x5
AHI08	2440 (8'0")	2390	12kg	"I"	100x50x5
AHI10	3050 (10'0")	3000	15kg	"I"	100x50x5
AHI12	3660 (12'0")	3610	18kg	"I"	100x50x5
AHI14	4270 (14'0")	4220	22kg	"II"	100x50x5
AHI16	4880 (16'0")	4830	25kg	"III"	100x50x5



MURRAY

GATES



WHITES RURAL

BALLIMORE GATES

Murray Ballimore Gates are manufactured at our Albury Manufacturing facility in regional Australia and feature:

- Full length 25NB top bar with double "I" Stay top
- Significantly more robust and visually more appealing gate
- 5mm pre-galvanised wire mesh
- 350 grade high tensile 25NB pipe
- All pipe is 2mm thick and hot-dip galvanised inside and out
- Fully welded notched joints to resist cracking
- 1170mm high
- Murray 'Shut the Gate Mate' sign



Scan for more information

Made in Australia
100% Australian Owned & Operated

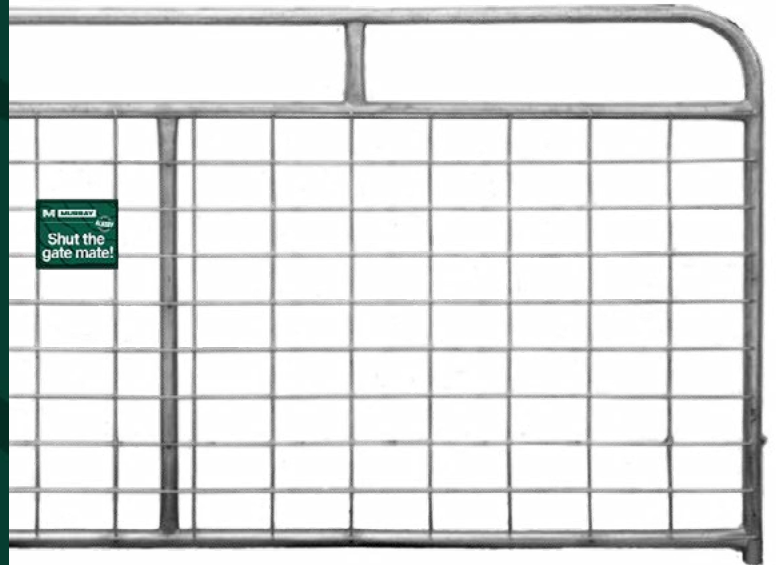

Code	Nominal mm (ft)	Actual (mm)	Stay Type	Weight (kg)	Weld Mesh (mm)
BALLIMORE FARM GATES					
ABA10	3050 (10')	3000	"I"	27kg	150x100x5
ABA12	3660 (12')	3610	"II"	31kg	150x100x5
ABA14	4270 (14')	4220	"II"	36kg	150x100x5
ABA16	4880 (16')	4830	"III"	40kg	150x100x5



FERAL GATES

Murray Feral "I" Stay Gates are manufactured at our Albury Manufacturing facility in regional Australia and feature:

- 1660mm high
- Tight 150mm x 100mm aperture (upper mesh)
- Super-tight 50mm x 100mm aperture (base mesh)
- 5mm pre-galvanised wire mesh
- 350 grade high tensile 25NB pipe
- All pipe is 2mm thick and hot-dip galvanised inside and out
- Fully-welded notched joints to resist cracking
- Murray 'Shut the Gate Mate' sign



Scan for more information

Made in Australia
100% Australian Owned & Operated

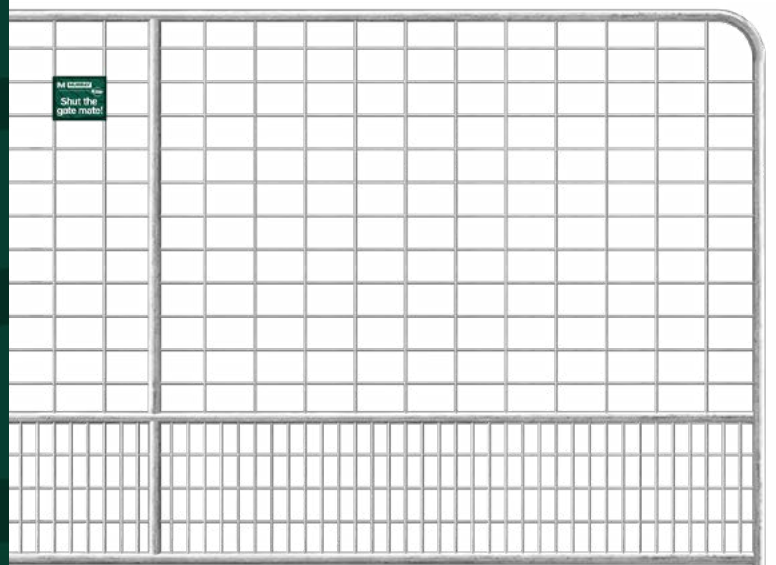

Code	Nominal mm (ft)	Actual (mm)	Stay Type	Weight (kg)	Weld Mesh (mm)
FERAL "I" STAY FARM GATES					
13012	3660 (12')	3610	"I"	52kg	150x100x5 / 50x100x5
13014	4270 (14')	4220	"II"	62kg	150x100x5 / 50x100x5

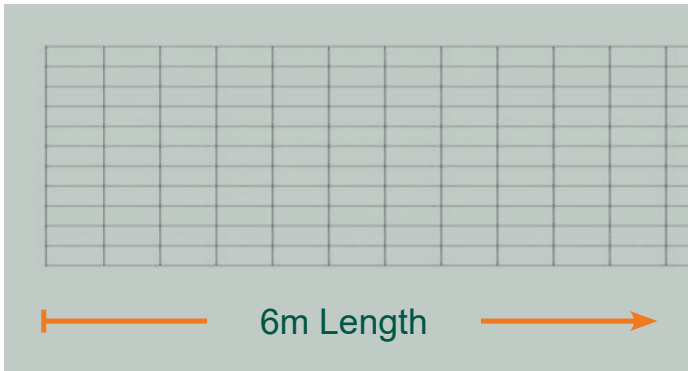

Code	Aperture (mm)	Width (mm)	Length (m)	Weight (kg)	Nom. Wire Dia. (mm)
SHEEP YARD MESH					
ASYM1	100 x 250	900mm	6m	12.7kg	5mm
ASYM2	100 x 250	1100mm	6m	15.3kg	5mm
ASYM3	100 x 200	900mm	6m	13.5kg	5mm
ASYM4	100 x 200	1100mm	6m	16.3kg	5mm
ASYM5	100 x 150	900mm	6m	14.9kg	5mm
ASYM6	100 x 150	1100mm	6m	18kg	5mm
ASYM7	100 x 250	900mm	6m	15.8kg	5.6mm
ASYM8	100 x 250	1100mm	6m	19.1kg	5.6mm
ASYM9	150/100 x 250	900mm	6m	10.6kg	4/5mm

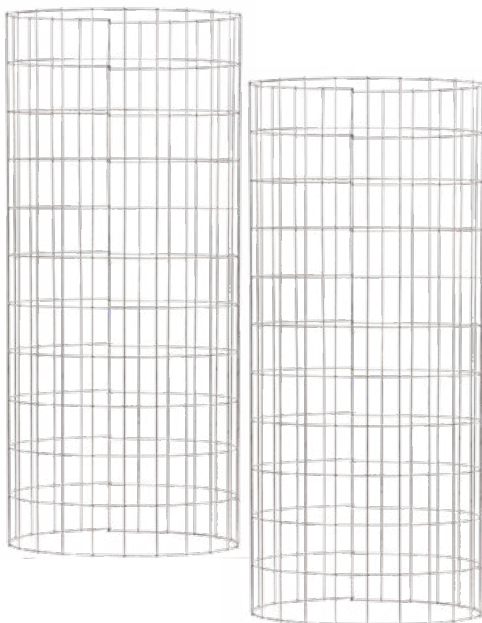

Code	Aperture (mm)	Diameter (mm)	Height (mm)	Length (mm)	Weight (kg)	Wire Dia. (mm)
TREE GUARDS						
ATREE	160 x 100	750	1760	2400	11.2kg	5

MURRAY

WELDED MESH

SHEEP YARD MESH

Murray Sheep Yard Mesh is manufactured flush with the outside edge of the perimeter wires at our Albury Manufacturing facility in regional Australia and available in four grades.

Light: 900mm high - 9 x 5mm line wires with the top two vertical apertures set at 150mm and lower six 100mm. 4mm horizontal cross wires at 250mm aperture.

Medium: 5mm wire with vertical apertures at 100mm and horizontal apertures set at 250mm.

Also produced in a 5.6mm wire for special orders.

Heavy: 5mm wire with vertical apertures at 100mm and horizontal apertures set at 200mm.

Extra Heavy: 5mm wire with vertical apertures at 100mm and horizontal apertures set at 150mm.



Scan for more information

Made in Australia

100% Australian Owned & Operated

TREE GUARDS

Pre-rolled tree guards

Murray Tree Guards are a heavy duty enclosure to protect young trees. Rolled before delivery and arriving ready for installation, they are manufactured at our Albury Manufacturing facility in regional Australia.

- Heavy duty enclosure
- Pre-rolled
- Protect young trees



Scan for more information

Made in Australia

100% Australian Owned & Operated

FARM GATES

TOP NOTCH™ "I" STAY GATES

Whites Rural Top Notch Gates are manufactured with embedded mesh that sits inside the gate. Along with end welds that are smooth and flush with the pipe, it makes for a stronger, safer and faster hanging gate.

Inbuilt Strength

Embedded wire mesh increases strength, improves durability.



Edge Protect

Safer for hands and livestock. No sharp edges!



Fast Fit

No need to cut wire mesh. Hinges fit fast!



- All pipe is a uniform 25NB
- 1145mm high, 2400-4800mm wide
- 5mm galvanised wire
- 200mm horizontal x 100mm vertical aperture
- Zinc-based coating completely covers pipe & welds
- Supplied with our "Shut the gate mate!" sign

Whites Rural Farm Gates are made to exacting standards from some of the best materials available, quality tested to ensure trouble-free fencing that is designed to last.

5 BAR FARM GATES

Whites Rural 5 Bar Farm Gates are made stronger for cattle and high pressure livestock situations, featuring horizontal hot-dipped galvanised pipe welded to the outer frame.

- All pipe is a uniform 25NB
- 1145mm high, 1000-4800mm wide
- Zinc-based coating completely covers pipe & welds



Nominal Size is the recommended gate opening

Code	Nominal mm (ft)	Actual (mm)	Stay Type	Weight (kg)	Weld Mesh (Nom. mm)
TOP NOTCH™ FARM GATES					
13122	875 (2'8")	825	-	8kg	200x100x5
13123	1075 (3'3")	1025	-	9kg	200x100x5
13124	1220 (4'0")	1170	-	10kg	200x100x5
13105	1525 (5'0")	1475	-	13kg	200x100x5
13106	1830 (6'0")	1780	-	14kg	200x100x5
13108	2440 (8'0")	2390	"I"	20kg	200x100x5
13110	3050 (10'0")	3000	"I"	22kg	200x100x5
13112	3660 (12'0")	3610	"I"	26kg	200x100x5
13132	3660 (12'0")	3610	"II"	29kg	200x100x5
13114	4270 (14'0")	4220	"II"	31kg	200x100x5
13116	4880 (16'0")	4830	"II"	36kg	200x100x5

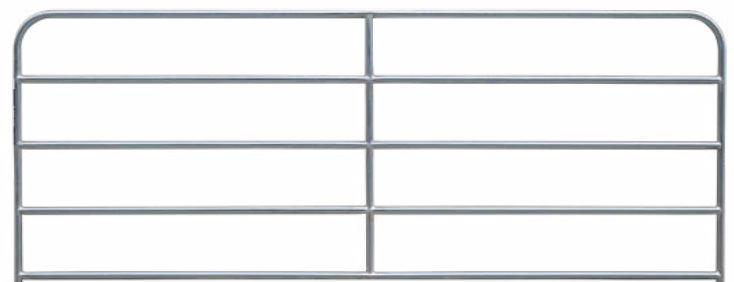

Nominal Size is the recommended gate opening

Code	Nominal mm (ft)	Actual (mm)	Stay Type	Weight (kg)	Pipe Mesh (Nom. mm)
5 BAR FARM GATES					
13204	1220 (4'0")	1170	-	13kg	25NB
13205	1525 (5'0")	1475	-	16kg	25NB
13206	1830 (6'0")	1780	-	18kg	25NB
13208	2440 (8'0")	2390	"I"	25kg	25NB
13210	3050 (10'0")	3000	"I"	29kg	25NB
13212	3660 (12'0")	3610	"I"	34kg	25NB
13214	4270 (14'0")	4220	"II"	41kg	25NB
13216	4880 (16'0")	4830	"II"	46kg	25NB

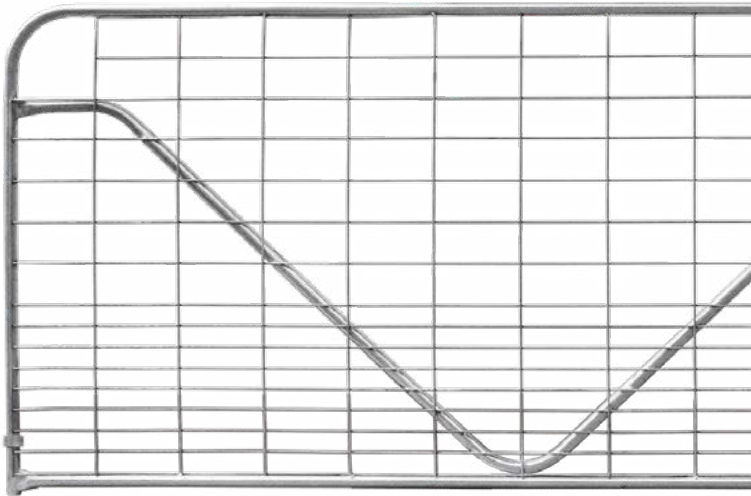

Nominal Size is the recommended gate opening

"N" STAY FARM GATES

Whites Rural "N" Stay Farm Gates feature a tighter mesh size for increased strength and protection. With a diagonal support brace running from the bottom to top corner, the range is available in left and right hand options.

- Variable mesh size for increased strength and protection
- Mesh apertures 190mm W, 45mm H (lower) and 90mm H (upper)
- All pipe is a uniform 25NB whilst Zinc-based coating completely covers pipe and welds
- Featuring collars for hanging and a diagonal support brace running from the bottom to top corner
- Available in left and right hand options (pack of 6 - 3L / 3R)

Code	Nominal mm (ft)	Stay Type	Weight (kg)	Weld Mesh (Nom. mm)
"N" STAY FARM GATES				
13310	3050 (10'0")	"N"	27kg	200x75x5
13312	3660 (12'0")	"N"	30kg	200x75x5
13314	4270 (14'0")	"N"	34kg	200x75x5
13316	4880 (16'0")	"N"	38kg	200x75x5

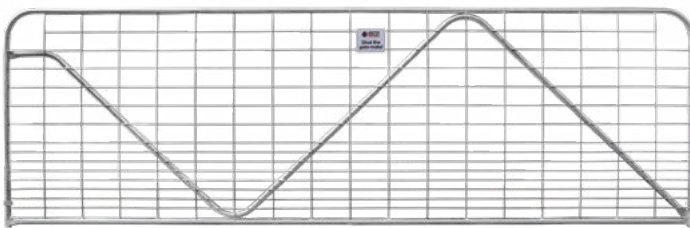

Code	Nominal mm (ft)	Actual (mm)	Stay Type	Weight (kg)	Weld Mesh (Nom. mm)
COLLARED "I" STAY FARM GATES (WA ONLY)					
13403	1075 (3'3")	1025	-	9kg	200x100x5
13404	1220 (4'0")	1170	-	10kg	200x100x5
13405	1525 (5'0")	1475	-	13kg	200x100x5
13406	1830 (6'0")	1780	-	14kg	200x100x5
13408	2440 (8'0")	2390	"I"	20kg	200x100x5
13410	3050 (10'0")	3000	"I"	22kg	200x100x5
13412	3660 (12'0")	3610	"I"	26kg	200x100x5
13414	4270 (14'0")	4220	"I"	31kg	200x100x5
13416	4880 (16'0")	4830	"I"	36kg	200x100x5
COLLARED "N" STAY FARM GATES (WA ONLY)					
13810	3050 (10'0")	3000	"N"	22kg	200x100x5
13812	3660 (12'0")	3610	"N"	26kg	200x100x5
13814	4270 (14'0")	4220	"N"	31kg	200x100x5
13816	4880 (16'0")	4830	"N"	36kg	200x100x5

COLLARED FARM GATES

Whites Rural Collared Farm Gates recognise the specific needs of the WA rural market. A range of regular, "I" stay & "N" stay gates has been developed with a pre-fitted collar as distinctly used in Western Australia farming communities.

- All pipe is a uniform 25NB
- 1145mm high, 2400-4800mm wide
- 5mm galvanised wire
- 200mm horizontal x 100mm vertical aperture
- Zinc-based coating completely covers pipe & welds
- Supplied with our "Shut the gate mate!" sign



GATE FITTINGS

GATE FITTING SETS

A wide range of galvanised steel gate fitting sets, all the components included. Hang everything from small pedestrian gates to the largest farm gates.

Available in Drop Latch and Ring Latch:

FG1 General Purpose Pack

- Screw-in 12mm latch and catch (ring latch only)
- Top through-post strap 16mm x 300mm thread length including backing plate
- Screw-in bottom gudgeon

FG2 Economy Pack

- Screw-in 12mm latch and catch
- Top strap assembly
- Screw-in 20mm bottom gudgeon

FG4 Heavy Duty Long Pack

- Screw-in 12mm latch and catch
- Top through-post strap 16mm x 400mm thread length including backing plate
- Bottom through-post gudgeon 16mm x 400mm thread length (all nuts and washers included)

FG9 Heavy Duty Pack

- Screw-in 12mm latch and catch
- Top through-post strap 16mm x 300mm thread length including backing plate
- Bottom through-post gudgeon 16mm x 300mm thread length (all nuts and washers included)

FG15 Multi-Fit Pack

- Screw-in 12mm latch and catch
- Top strap assembly
- Screw-in / weld-on bottom gudgeon

FG20 Collared Pack (WA only)

- Screw-in 12mm latch and catch
- Top and bottom through-post hinge assemblies 20mm x 400mm thread length with U-shaped hinge (all nuts and washers included)

Ring Latch

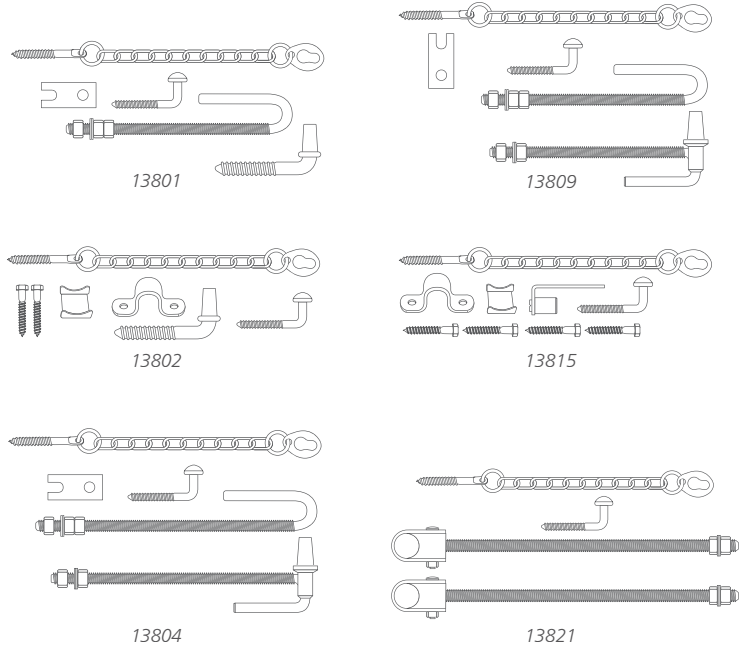

Drop Latch

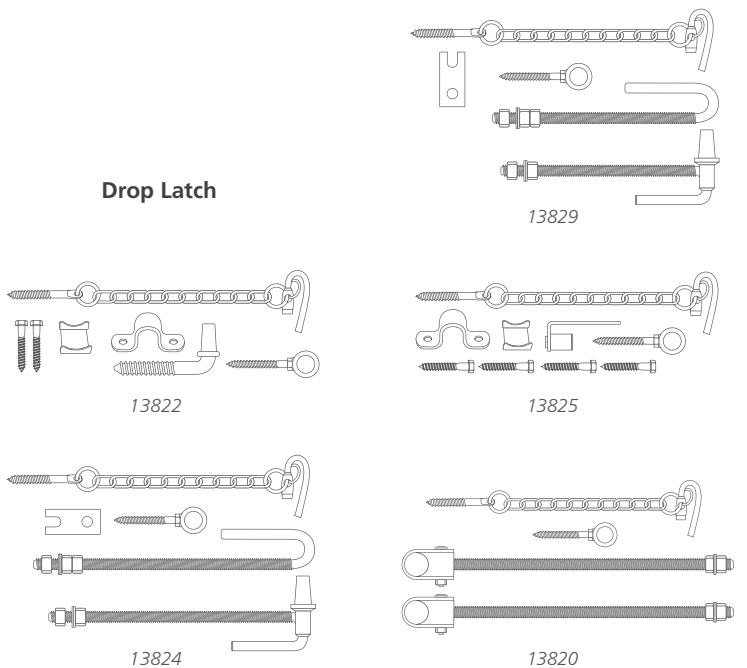

Ring Latch Code	Drop Latch Code	Product	Pack	Carton Qty	Weight (kg)
GATE FITTING SET - RING LATCH & DROP LATCH					
13801	-	General Purpose Pack	FG1	5	1.9kg
13802	13822	Economy Pack	FG2	10	1.6kg
13804	13824	Heavy Duty Long Pack	FG4	5	2.6kg
13809	13829	Heavy Duty Pack	FG9	5	2.5kg
13815	13825	Multi-Fit Pack	FG15	10	1.3kg
13821	13820	Collared Gates (WA only)	FG20	5	2.6kg

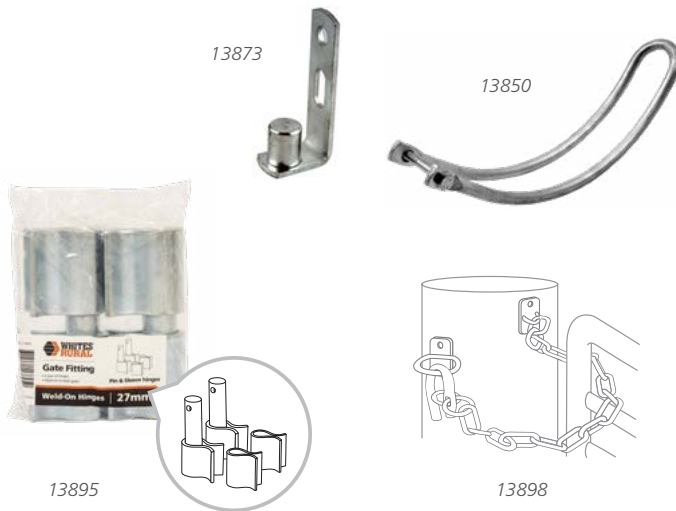

INDIVIDUAL FITTINGS

Galvanised steel screw-in and weld-on gate fittings.

Latches

Screw-on available in drop and ring types.

Weld-on drop latch suitable for square or round posts.
Can be screw-fixed. Low profile safer for animals.

Strap and Gudgeon

Top strap screw-in type.

WG34 gudgeon weld-on type.

G13 gudgeon features long plate - weld-on or screw-in.

Pins and Sleeves

Featuring pin-lock hole for added peace of mind where needed. Simply weld into place.

Each packs contains 2 pairs (2 x pins and 2 x sleeves)

Double Gate Bow

Self-locating latch for double end gates. Suits 25NB gates.

Code	Product	Type
INDIVIDUAL FITTINGS		
13830	Ring Latch & Catch	Screw
13833	Drop Latch & Eyelet	Screw
13862	Top Strap 25mm S3	Screw / Weld-on
13873	Gudgeon 25mm G13	Screw / Weld-on
13875	Gudgeon 25mm WG34	Weld-on
13895	Pins & Sleeves 27mm	Weld-on
13896	Pins & Sleeves 20mm	Weld-on
13897	Pins & Sleeves 16mm	Weld-on
13898	Drop Latch	Weld-on
DOUBLE GATE BOW		
13850	Double Gate Bow	Screw

SPECIALTY GATE FITTINGS

End Assembly Gate Fittings

Designed for the Stockpost Anchor Post, the fittings attach around the anchor post with no screwing or welding required.

Top strap & gudgeon pack to hinge the gate;
drop latch pack to lock the gate.

Bolt-on Double Gate Latch

Robust fitting suitable for securing 25NB double gates.

No need for screwing or welding; just position the latch on the gate frame and tighten the bolt to attach.

Pedestrian Gate Pack

Use with pedestrian gates, the pack features an easy access "D" latch and all the components.

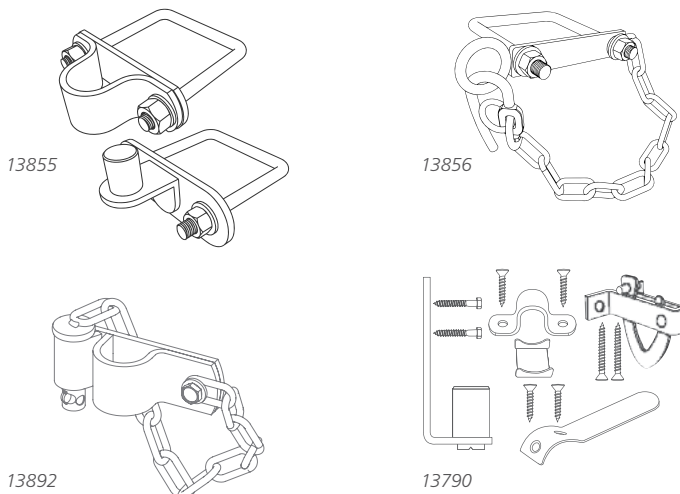

Code	Product	Carton Qty	Weight (kg)
SPECIALTY GATE FITTING SETS			
13855	End Assembly Top Strap & Gudgeon	5	1.5kg
13856	End Assembly Drop Latch & Eyelet	5	0.8kg
13892	Bolt-on Double Gate Latch	20	0.7kg
13790	"D" Latch Gate Pack	20	0.7kg

HEAVY NETTING

RURAL NETTING

Whites Rural Heavy Netting is a versatile heavily galvanised netting for rural and heavy duty applications.

- Reverse twist construction
- Double selvedge wires for added strength
- Heavily galvanised

Netting with a 4cm aperture, 1.4mm wire diameter & is available in varying heights. Suggested uses are:

- 30cm** - reconditioning of existing fences, garden edging
- 60cm** - reconditioning of existing fences, poultry
- 90cm** - rabbit proofing, boundary fencing & tree guards
- 105cm** - rabbit proofing, boundary fencing & tree guards
- 120cm** - boundary and feral fencing, poultry
- 180cm** - feral fencing, poultry and animal enclosures

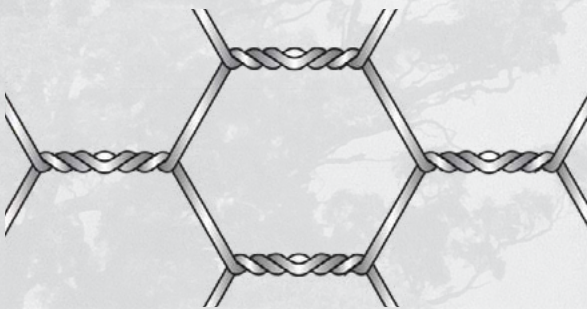

Code	Height	Aperture nom.	Wire Dia. nom.	Roll Length	Roll Weight	Pallet Qty	Galv. Coating
HEAVY NETTING							
10451	30cm	4cm	1.4mm	50m	13kg	48	Heavy
10452	60cm	4cm	1.4mm	50m	26kg	18	Heavy
10454	90cm	4cm	1.4mm	50m	36kg	9	Heavy
10474	90cm	4cm	1.4mm	100m	75kg	9	Heavy
10455	105cm	4cm	1.4mm	50m	42kg	9	Heavy
10475	105cm	4cm	1.4mm	100m	86kg	9	Heavy
10456	120cm	4cm	1.4mm	50m	48kg	9	Heavy
10458	180cm	4cm	1.4mm	50m	74kg	9	Heavy

BOUNDARY NETTING

Whites Rural Heavy Duty Boundary Netting has a 5cm aperture, 1.6mm wire diameter & is available in varying heights. Suggested uses are:

- 90cm** - farm fencing, dogs & tree guards
- 120cm** - feral fencing, animal enclosures & tree guards
- 180cm** - feral fencing, animal enclosures & tennis courts



Code	Height	Aperture nom.	Wire Dia. nom.	Roll Length	Roll Weight	Pallet Qty	Galv. Coating
HEAVY NETTING - BOUNDARY							
10653	90cm	5cm	1.6mm	50m	37kg	9	Heavy
10655	120cm	5cm	1.6mm	50m	48kg	9	Heavy
10657	180cm	5cm	1.6mm	50m	71kg	9	Heavy

FARM MESH



FARM MESH HEAVY DUTY

Whites Rural Farm Mesh Heavy Duty is a 2.5mm general purpose welded mesh for heavy duty applications.

- Heavy welded construction
- Flush cut edges
- 2.5mm galvanised wire

Whites Rural Farm Mesh can be used for a variety of applications, including:

- Cages and animal enclosures
- Drainage grids
- Fencing and tree guards
- Trailer enclosures

FARM MESH HEAVY DUTY HEAVILY GALVANISED

A heavily galvanised version of the Whites Rural Farm Mesh Heavy Duty.

- Heavily galvanised to AS4534
- 75mm x 50mm aperture
- 2.5mm for heavy duty applications
- Heavy welded construction
- Flush cut edges

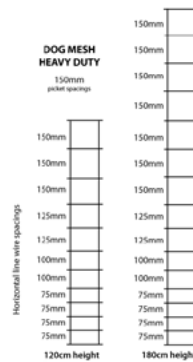

DOG MESH HEAVY DUTY

Whites Rural Dog Mesh Heavy Duty is an ideal fencing mesh to keep larger dogs and similar sized animals within a boundary, or out of garden beds and yards.

- Graduated mesh
- Heavy welded construction
- Flush cut edges
- 2.5mm galvanised wire

Line and picket wires have been strengthened for added rigidity. The graduated mesh is available in 120cm & 180cm heights, with smaller apertures at the base to fence puppies and smaller animals.

Code	Height (cm)	Aperture (mm)	Wire Diameter	Roll Length	Roll Weight	Pallet Qty	Galv. Coating
HEAVY DUTY FARM MESH							
21982	90	75 x 50	2.5mm	30m	34kg	9	Standard
21983	120	75 x 50	2.5mm	30m	46kg	9	Standard
21988	180	75 x 50	2.5mm	30m	69kg	9	Standard
21980	90	100 x 100	2.5mm	30m	22kg	16	Standard
21981	120	100 x 100	2.5mm	30m	29kg	16	Standard
21989	180	100 x 100	2.5mm	30m	43kg	9	Standard
HEAVY DUTY FARM MESH - HEAVILY GALVANISED							
22683	90	75 x 50	2.5mm	30m	34kg	9	Heavy
22684	120	75 x 50	2.5mm	30m	46kg	9	Heavy
HEAVY DUTY DOG MESH							
22004	120	Graduated	2.5mm	30m	23kg	16	Standard
22008	180	Graduated	2.5mm	30m	32kg	16	Standard

FENCING

HORSE SIGHT FENCE WIRE

Used as a top wire on horse fencing to increase visibility and prevent injury to horses.

- White PVC coating improves visibility
- Reduces damage to fences and injury to horses
- UV stabilised PVC coating



*5.2mm total diameter including PVC coating

Code	Wire	Tensile Strength	Coil Length	Coil Weight	Sling Qty	Galv. Coating	Rec. Tension Breaking Strain
HORSE SIGHT FENCE WIRE							
10169	5.2mm*	Soft	400m	43kg	5	Standard	2.0kn, 6.0kn
HANDYFENCE™							
10011	2.50mm	Medium	300m	11.6kg	10	Standard	1.3kn, 3.7kn
10012	3.00mm	Soft	250m	13.9kg	10	Standard	1.2kn, 3.0kn

HANDYFENCE™

Whites Rural Handyfence coils, a great option for smaller fencing runs or for quick and easy repairs to fences.



DROPPERS

Whites Rural Fence Droppers are manufactured from high grade steel and heavily galvanised to ensure long life. Use with barbed wire or plain wire.

- Manufactured from high tensile steel
- Heavily galvanised for long life
- Pack of 25 includes tool and clips



Code	Product	Sling Qty	Weight (each)	Coating
STEEL FENCE DROPPERS				
10510	63.5cm Droppers	25	6kg	Hot Dip Galvanised
10511	81.5cm Droppers	25	9.4kg	Hot Dip Galvanised
10512	94cm Droppers	25	10.6kg	Hot Dip Galvanised
10514	107cm Droppers	25	12.2kg	Hot Dip Galvanised
10515	117cm Droppers	25	13.3kg	Hot Dip Galvanised
10516	Dropper Clips 500gm	-	-	-

FARMLITE™ HINGED JOINT

Farmlite Hinged Joint is a cost-effective solution for hobby farms and smaller rural properties. Made from 2.00mm standard galvanised wires.

Code	Product	Tensile Strength	Roll Length	Roll Weight	Pallet Qty	Galv. Coating	Line Wire
FARMLITE™ HINGED JOINT							
10281	8/90/15	Medium	100m	42kg	9	Standard	2.0mm
10282	8/115/15	Medium	100m	46kg	9	Standard	2.0mm
10272	8/115/15	Medium	50m	24kg	16	Standard	2.0mm

DRIVERS, LIFTERS & SPINNERS



12207



12205



12203

CONTRACTOR GRADE

Contractor "Grip & Lift" Post Lifter

Robustly designed post lifter featuring parallel gripping surface with hardened steel grips. Heavy duty contractor grade construction.

- Hardened steel grips
- Suits most fence posts including Stockpost XL
- Galvanised steel; high tensile bolts

Contractor Post Drivers

Designed with reinforced handles and unique anti-shake handle to reduce vibrations transferred to the operator. Available in two sizes to suit standard posts and larger intermediate posts. Features include:

- Reinforced fully welded handles
- Balanced handles and head, reduces strain
- Anti-vibration collar

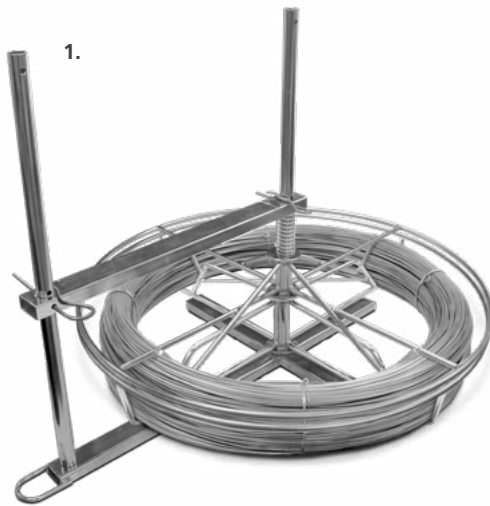

1.

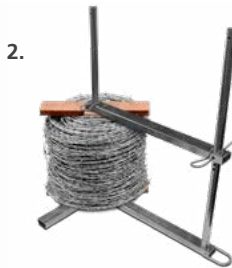

2.

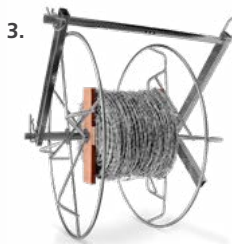

3.

Three-Way Wire Spinner

Heavy Duty Three-Way Wire Spinner for smooth payout of plain & barbed wire. Zinc-plated, heavy duty steel construction. Made tough for Australian conditions.

Three different configurations make for an all-in-one tool to make fencing faster:

1. Fence Wire Spinner
Large diameter suits all fence wire types
2. Barbed Wire Spinner
Suitable for all types of barbed wire on reels
3. Mobile Hand-Cart
Turn unit on side for a mobile barbed wire hand-cart

STANDARD RANGE

Whites Rural Standard range of lifter, driver and wire spinner are an economical alternative to the contractor range, available in a durable zinc-plated finish.

Post Lifter

Heavy steel construction. Simply place post in jaw and use the lever action to easily remove steel posts.

Post Driver

Heavy steel construction, weighted balanced head.

Fence Wire Spinner

Central hub is designed for smooth, easy payout, and is adjustable to reduce spin and overrun for faster payout. Includes barbed wire attachment.



Code	Product	Weight (kg)
STANDARD - LIFTER, DRIVER & WIRE SPINNER		
12200	Post Lifter	8.3kg
12201	800mm Post Driver	6.8kg
12110	Wire Spinner	11.5kg

STRAINERS & STRAINING TOOLS

FENCE & WIRE STRAINERS

Wire Chain Strainer

Whites Rural Contractor Chain Strainer is a proven design with hard wearing features, built tough to last. Ideal for straining fence wire, barbed wire and pre-fabricated fencing, it features:

- Swivel Jaw Attachment for use on either side of fence
- Removable Long Handle
- Heavy Duty Steel Rivets
- 1.8m Gold-Passivated Chain
- Smooth-Grip Jaws & Anchor Hook



Fabricated Farm Fencing Strainers

Whites Rural Contractor Fabricated Farm Fencing Strainer is used in conjunction with a chain strainer, it allows for easy straining and installation of fabricated farm fencing.

Available in two sizes:

- 1.2m, 3 straining points, 4 pegs, ideal for most farm fencing
- 1.6m, 5 straining points, 6 wedged pegs, ideal for exclusion fencing

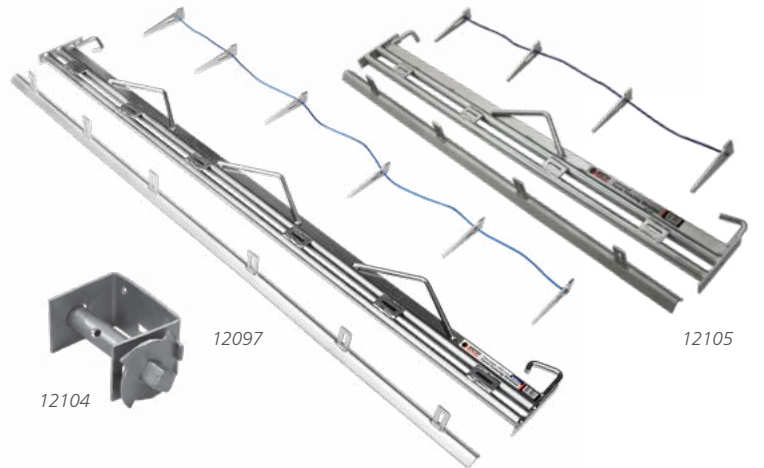

Agri-Wire Strainer

Whites Rural Agri-Wire Strainer is a specialised strainer for trellis wire in vineyards. Featuring a traditional cam-lock mechanism, the design makes it an easy and effective device for straining wire at the end of the trellis.

Suitable for all high tensile wires up to 3.15mm and ideal for use with Murray™ Trellis Wire.

Code	Product	Weight (kg)
STRAINING TOOLS		
12302	Contractor Chain Strainer	3.8kg
12105	Contractor Fabricated Farm Fencing Strainer 1.2m	9.1kg
12097	Contractor Fabricated Farm Fencing Strainer 1.6m	13kg
12109	Replacement Wedge Pack (1.2m)	0.65kg
AGRI-WIRE® STRAINER		
12104	Agri-Wire Strainer	

Permanent Wire Strainers

Whites Rural Strainers are available in galvanised, plastic insulated and porcelain insulated, and feature:

- Smooth ratchet action
- Releasable ratchet
- Long-life galvanised steel body
- High quality spring-locking clip
- Up to 4mm wire capability
- 16mm square drive or 8mm hex key for tightening (except 12099)



Code	Product	Pack Qty
PERMANENT WIRE STRAINERS		
12106	Permanent Wire Strainer	25
12500	Insulated Perm. Wire Strainer - Plastic	20
12501	Insulated Perm. Wire Strainer - Porcelain	20
12099	Permanent Wire Strainer	25
12090	Permanent Wire Strainer - Bucket	40



STAPLING



ST400i



ST400i Impulse Fencing Staples & Fuel Cell Pack

STOCKade[®] Impulse[®]

STOCKade Impulse power staplers combine faster fencing with hose-free portability in a gas cartridge gun.

ST400i Cordless Fence Post Staple Gun

- Portable – no need for compressors or air lines
- Efficient – fast, high output design drives up to 2 staples per second
- Reliable – Fuel Injection Technology delivers consistent power every time
- Fuel & Battery Indicator – never get caught short on the fence line
- Adjustable depth of drive for greater flexibility with staple placement
- V-Notch guide and wire guide to ensure correct staple placement and improved holding power

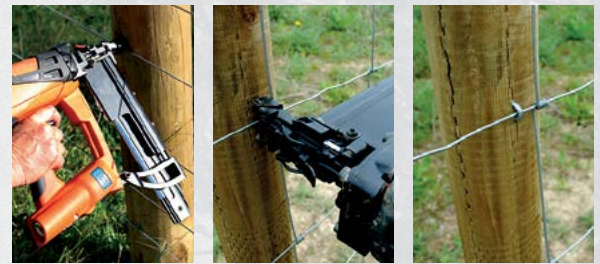

ST315i Cordless Dropper Fencing Stapler Gun

- Portable – no need for compressors or airlines
- Efficient – fast, high output design drives up to 2 staples per second
- Lightweight design for comfort during periods of high use
- Top Load Magazine for fast reloading to minimise down-time

V-Notch Guide ensures correct staple placement and improved holding power

ST400i ST315i and ST400 Staples

- Stockade staples are engineered for superior corrosion resistance and long lasting hold even in the world's toughest environments
- 90% Zinc, 10% Aluminium pre-galvanised 240gm heavy duty coat provides superior corrosion resistance
- Specified wire tensile strength and divergent point design enhances holding power
- Waterproof collation tape for all weather performance
- 4mm wire diameter to suit ST400i and ST400
- 3.15mm wire diameter to suit ST315i



ST315i



ST315i Impulse Fencing Staples & Fuel Cell Pack

Code	Product	Per Packet	Weight (kg)
STOCKade[®] IMPULSE[®] POWER STAPLING			
12440	STOCKade ST315i Impulse Power Stapler		6.6kg
12441	STOCKade 33 x 3.15mm Impulse Barbed Staples	2000	6.7kg
12453	STOCKade 40 x 3.15mm Impulse Staples	2000	7.2kg
12445	STOCKade ST400i Impulse Power Stapler		4.2kg
12446	STOCKade 40 x 4.0mm Impulse Barbed Staples	1000	7.75kg
12448	STOCKade 50 x 4.0mm Impulse Barbed Staples	1000	10.2kg
STOCKade[®] IMPULSE[®] FENCING ACCESSORIES			
12439	STOCKade ST315i Battery		0.09kg
12449	STOCKade ST400i Battery		0.09kg

STOCKade[™]
makes fencing

Exclusively distributed in Australia by Whites Rural

STAPLING

STOCKade® Pneumatic

The STOCKade pneumatic power stapler is designed for faster fencing and reduced manual effort.

ST400 Pneumatic Fence Post Staple Gun

- Adjustable power for high-density timber
- Reliable for high volume fence construction
- Adjustable depth of drive for greater flexibility with staple placement
- Top Load Magazine for fast reloading to minimize down-time
- Sequential Trigger System for superior operator safety
- Adjustable Air Deflector – deflects discharged air away from the operator for improved comfort
- Swivel coupling for greater flexibility and added convenience



ST-400

STOCKade
makes fencing

Exclusively distributed in Australia by Whites Rural

Code	Product	Per Packet	Weight (kg)
STOCKade® PNEUMATIC POWER STAPLING			
12430	STOCKade ST400 Power Stapler		6.6kg
12454	STOCKade 50 x 4.0mm Barbed Staples	1000	10kg

FENCING STAPLES

Galvanised double pointed "U" nail for securing wire to timber frames and posts. Plain or barbed staples for added holding power.

- Galvanised for maximum durability
- Razor sharp points for fast, easy driving
- Suitable for securing wire, mesh and netting

Available in hot-dipped galvanised for longer life.



Code	Product	Qty Per Packet	Weight (kg)	Carton Qty
GALVANISED STAPLES				
12503	50 x 4.0mm Barbed	50	500g	24
12509	40 x 4.0mm Barbed	52	500g	24
12513	30 x 4.0mm Barbed	65	500g	24
12416	25 x 3.15mm Plain	132	500g	24
12502	50 x 4.0mm Barbed	300	3kg	8
12506	40 x 4.0mm Barbed	315	3kg	8
12512	30 x 4.0mm Barbed	390	3kg	8
12412	25 x 3.15mm Plain	795	3kg	8
12517	50 x 4.0mm Barbed	1500	15kg	1
12518	40 x 4.0mm Barbed	1600	15kg	1
HOT-DIPPED GALVANISED STAPLES				
12504	50 x 4.0mm HDG Barbed	500	5kg	4
12505	50 x 4.0mm HDG Barbed	1500	15kg	1
12511	40 x 4.0mm HDG Barbed	1600	15kg	1



FASTENERS

STOCKade[®] RINGfast[™]

The RINGfast pneumatic ring fastening tool quickly and consistently secures ring fasteners.

Faster than manual tools, reliable and relatively effortless, the pneumatic operation produces consistent rings fast, reducing manual effort and improving productivity.

The tool has been designed with an ergonomic grip and is balanced for comfortable operation.

- Quickly and consistently secures ring fasteners
- Reduces manual effort, improves productivity
- Ergonomic and comfortable to operate
- Zinc-Aluminium coating for longer life



12308

12305

12301



12300

JAMBRO[®] RING FASTENER

Whites Rural exclusively distributes the Jambro Ring Fastener Gun and Clips in Australia. Fast and reliable, this manual gun will fasten to a rate of 25 metres per minute.

The stainless steel jaws and precision body casting ensure quick and easy loading and firing. Use with Jambro high tensile ring clips.

- Faster fencing, 25 metres per minute
- Stainless steel jaws
- High tensile ring fasteners
- Zinc-Aluminium coating for longer life

WOOL BALE FASTENERS

Super sharp, galvanised and pressed-cut to ensure the finest point. Penetrates fabric first time.

Designed to be used in conjunction with Australian Wool Exchange (AWEX) standards.

Code	Product	Per Packet	Weight (kg)
STOCKade[®] RINGFAST[™] PNEUMATIC RING FASTENERS			
12308	STOCKade RINGfast Pneumatic Tool (bonus case)		1.5kg
12305	STOCKade RINGfast Ring Fasteners	1000	0.7kg
STOCKade[®] JAMBRO[®] RING FASTENERS			
12300	Jambro Ring Fastener Gun		0.4kg
12301	Jambro Standard Ring Fasteners	1000	1kg



12331

12334

12335

Code	Product	Per Packet	Weight (kg)	Carton Qty
WOOL BALE FASTENERS				
12330	Wool Bale Fasteners	100	500g	24
12331	Wool Bale Fasteners	300	1.5kg	8
12334	Wool Bale Fasteners	700	3.5kg	4
12335	Wool Bale Fasteners		15kg	1

MAX Engineering

Exclusively patented system, *MaxTensor's* all metal construction is designed for maximum quality, reliability and ease of use when joining and tensioning wire.

MAX Usability

Ergonomically designed for effortless practicality and long lasting performance, *MaxTensor* makes joining, straining and repairing fences easier.

MAX Reliability

With millions sold globally, *MaxTensor's* patented system is industry tested and proven against the best the world has to offer. Made in the EU to strict specifications.

Exclusively distributed throughout Australia & New Zealand by Whites Rural.



Barbed Wire - *MaxTensor*
Medium Joiner & Tensioner will fit up to 1.57mm barbed wire.



High Tensile Wire - *MaxTensor*
is specially designed for wire with a high breaking strain.



Electric Fencing - *MaxTensor's*
all metal construction means there is no break in the current.



Zinc Aluminium - *MaxTensor's*
cam wedge provides a strong grip to hold Zn-Al coated wire.

All Metal Construction

Joiners & Tensioners for fencing wire, horticultural wire & fabricated fence



MaxTensor is a complete range of joiners, tensioners, end post terminators and tensioning tools



12157



12159



12160

12161

Code	Product	Per Packet	Carton Qty
MaxTensor® WIRE JOINERS & TENSIONERS			
12157	MaxTensor Medium Joiner - Blister Pack	20	6
12156	MaxTensor Medium Joiner - Contractor Pack	100	2
12155	MaxTensor Medium Joiner - Bulk Pack	250	-
12159	MaxTensor Large Joiner - Blister Pack	10	6
12158	MaxTensor Large Joiner - Bulk Pack	150	-
MaxTensor® TENSIONING TOOLS (WITH 5 BONUS MEDIUM JOINERS)			
12160	MaxTensor Polymer & Steel Core Tensioning Tool		
12161	MaxTensor Heavy Duty Steel Tensioning Tool - Contractor Grade		



FARM PAK™ TIE WIRE

Whites Rural Farm Pak Tie Wires are wound onto a 'no tangle' dispenser pack for ease of use. The 3kg packs are light enough to carry, yet contain sufficient wire for most applications around the farm.

- Heavily galvanised wire
- 'No tangle' dispenser
- Easy to handle 3kg packs
- Soft, easy to tie



Code	Product	Length	Weight (kg)	Carton Qty
FARM PAK™ TIE WIRES				
50223	2.50mm Heavy Galvanised	80m	3kg	5
50224	2.00mm Heavy Galvanised	120m	3kg	5
50225	1.57mm Heavy Galvanised	200m	3kg	5



FENCING ACCESSORIES

Heavily Galvanised Pre-Cut Tie Wires

Easy to work with low tensile, pre-cut 300mm lengths. A great time-saver alternative to cutting longer coils to suit. Heavily galvanised & supplied in re-usable handy packs.

Horse-Safe Fence Post Caps

Hi-visibility and UV-resistant featuring three-slot pattern to hold 5mm hot wire and/or 12-40mm electric tape. White colour for horse safety. Suit standard 'Y' or larger intermediate posts.

Standard Post Caps

Unique Fin Grip™ system, snugly fits post with no need to tie down. With side holes for fence wire to pass through.

Stay Pins

Hot-dipped galvanised pre-cut 10mm rod lengths ideal for joining timber rails and posts. Long lasting, especially in CCA treated timbers. 300mm length for thicker timber and extra support.

Fencer's Tool

Makes tying off fence wire easy. Convenient pocket-size. For use with up to 4.00mm wire diameter.

Fence Post Clips

Fixes plain or barbed wire to steel fence posts. Easy to use, each pack includes an application tool.

Code	Product	Per Packet	Weight (kg)	Carton Qty
FENCER'S TOOL				
12005	Fencer's Tool	-	0.1kg	-
FENCE POST CLIPS				
12319	Fence Post Clips (with tool)	250	1.4kg	8
HEAVILY GALVANISED PRE-CUT TIE WIRES				
71541	HG Pre-Cut Tie Wire 3.15mm x 300mm	approx 230	4kg	3
71543	HG Pre-Cut Tie Wire 2.50mm x 300mm	approx 340	4kg	3
HORSE-SAFE POST CAPS				
12348	Horse-Safe Post Caps	-	4.3kg	40
12349	Horse-Safe Post Caps XL	-	3.2kg	20
FENCE POST CAPS				
12322	Post Caps Yellow - 60mm	40	0.8kg	10
STAY PINS				
14340	Stay Pins Galvanised 10 x 300mm	50	9.5kg	

PLIERS & CUTTERS

CONTRACTOR GRADE

Genuine Knipex® Quality

Knipex Professional Wire Cutting Plier made in Germany, from heat-treated Cr-V steel, with a tough cutting edge and a comfortable ergonomic design.

Genuine Toledo® Pliers and Cutter

Durable and robust, designed for fencing. Made from chrome-molybdenum steel and featuring specially heat-treated hardened jaws and cutting edges. Parrot-beak, bullnose and pocket cutter styles.



12001



12041

12042

12043

12044

Code	Product	Size	Weight (kg)	Carton Qty
PROFESSIONAL PLIERS & CUTTERS				
12001	Knipex Professional Wire Cutting Plier	200mm	0.4kg	20
12041	Toledo Pocket Bolt Cutter	-	0.3kg	60
12042	Toledo Professional Parrot Beak Plier	270mm	0.7kg	24
12043	Toledo Professional Fencing Plier	260mm	0.5kg	36
12044	Toledo Professional Fencing Plier	300mm	0.8kg	24

STANDARD RANGE

Whites Rural Fencing Pliers

Whites Rural multi-use fencing pliers are strong, durable, and reliable to make fencing easy. Available in two styles:

Bullnose Pliers

- 3 wire cutters
- 2 different wire grips - suits any diameter

Parrot Beak Pliers

- Wire cutter, grips and hammer end
- Staple puller 'parrot beak'



12002

12003

12004

Code	Product	Size	Weight (kg)	Carton Qty
FENCING PLIERS				
12002	Fencing Plier - Parrot Beak	250mm	0.6kg	5
12003	Fencing Plier - Bullnose	250mm	0.6kg	5
12004	Fencing Plier - Bullnose	300mm	0.7kg	5



Whites Group Pty Ltd

ABN 25 001 845 478

SYDNEY
5 Dolerite Way,
Pemulwuy,
NSW 2145

ALBURY
109 Boronia Rd,
Albury,
NSW 2640

BRISBANE
U4, 15 Seeana Place,
Heathwood,
QLD 4110

MELBOURNE
64 Colemans Rd,
Dandenong South,
VIC 3175

TOWNSVILLE
13 Crocodile Cres,
Mount St John,
QLD 4818

PERTH
53 Collopy Rd,
Perth Airport,
WA 6105

ADELAIDE
18 Bradford Way,
Cavan,
SA 5094

Enquiries: 1300 559 732 Fax: 1300 559 762 Email: info@whitesrural.com.au
Specifications referred to in this publication are subject to change,
variation and/or improvement without notice.

For the most up-to-date details on all our rural products, visit our website at
www.whitesrural.com.au

© WHITES RURAL, STOCKPOST, UTE PACK, and STIFF STAY are registered trademarks of Whites Group Pty Ltd
™ MURRAY, TOP NOTCH, FARM PAK, FARMLITE, HANDYFENCE, FIN GRIP and RINGfast are trademarks of Whites Group Pty Ltd
© MaxTensor is a registered trademark of Shiny Works, S.L. © STOCK-ade, Impulse & Jambro are registered trademarks of Paslode Pty Limited
© Knipex is a registered trademark of KNIPEX-Werk C. Gustav Putsch KG © Bezinal is a registered trademark of NV Bekaert SA
© Famous Toledo Excellence By Design is a registered trademark of Tridon Australia Pty Ltd

